

Fixed and Scanning Infrared Radiometers for Combustion Studies

Kathy Underhill-Shanks and M. Keith Hudson

Department of Applied Science, Graduate Institute of Technology
University of Arkansas at Little Rock, Little Rock, AR 72204 USA

Matthew J. Russo

Hercules Aerospace, 1101 Johnson Ave., McGregor, TX 76657 USA

ABSTRACT

The feasibility of using lead selenide (PbSe) detectors and simple electronic circuitry, including a 600 Hz chopper and chopper frequency/phase reference circuit, to detect infrared emissions from flames and rocket motor plumes was demonstrated. A fixed wavelength radiometer, employing one-inch interference filters and mechanical phase adjustment, was constructed to monitor the 4.4- μm carbon dioxide band and the 2.7- μm water vapor band. The fixed wavelength radiometer was used in flame studies and in several rocket motor tests. The design of the fixed wavelength radiometer was modified to produce a spectroradiometer. The spectroradiometer system included a circular variable filter (CVF) having a wavelength range of 2.1 to 4.7- μm , which allowed wavelength scanning. The circuitry for the spectroradiometer was improved to include a time constant, which could be adjusted electronically, and an electronic phase adjustment. The spectroradiometer was used to monitor numerous rocket motor firings.

The infrared emissions detected by the spectroradiometer included: the water vapor band at 2.7 μm , the hydrogen chloride band at 3.5 μm , and the carbon dioxide band at 4.4 μm .

Keywords: IR radiometer, rocket plume monitoring, PbSe detector, engine health, combustion diagnostics, infrared spectroscopy, IR emission

Introduction

Since World War II, the scientific study of emissions from hot gases has been an increasing area of interest. The earliest research used model systems to simulate jet exhaust.^[1] Later investigations dealt mostly with infrared emissions from rocket plumes.^[2] A large percentage of infrared rocket plume emission data was collected in the spectral region from one to five micrometers (μm). Two distinct bands occur between these two wavelengths. The first band is centered at 2.7 μm and is attributed to water vapor and an overtone band of carbon dioxide. The other band, centered at 4.4 μm , is much more intense and corresponds to carbon dioxide. Figure 1 shows an infrared spectrum obtained from a Bunsen burner. Both the water vapor and carbon dioxide bands are present.

Equipment currently available for collecting data from rocket plumes is sophisticated, and often includes Fourier Transform Infrared (FTIR) instrumentation or imaging systems. Rapid scanning instrumentation for both spatial and spectral measurements in rocket plumes has been described by various research groups.^[3-5] Many of the experiments conducted were primarily spatial in nature, and required the use of liquid nitrogen cooled indium antimonide detectors. These studies provided little, if any, spectral information.

Existing systems are not an economical means for obtaining infrared emission data from rocket ground testing. The expense is especially important when the detection system is used in conjunction with experimental rocket propel-

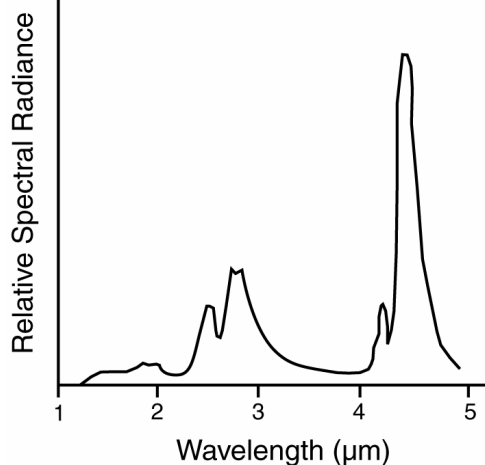

Figure 1. Infrared emission spectrum of a Bunsen burner flame. Peaks in the 2–3 μm region are attributed to water vapor and an overtone band of carbon dioxide. Peaks in the 4–5 μm range are attributed to carbon dioxide.

lants or new rocket motor configurations, which may be prone to catastrophic failure. Typically, these systems are also not portable. Portability is crucial if instrumentation is to be used in the field. The instrumentation described in this paper is very simple and inexpensive. While primarily meant to monitor emissions at a specified wavelength as a function of time, the instrument can also scan the spectrum in the 1–5 μm region. The data obtained from the instrumentation can be used for characterization of rocket propellants, and for signature studies. It can be correlated with other data such as chamber pressure.

Experimental

Fixed Wavelength Radiometer

To ascertain the feasibility of using a lead selenide (PbSe) detector in conjunction with flame and plume studies, a prototype infrared radiometer system was constructed. This prototype was based on previous designs by Hudson et al.^[6–8] In this prior work, a room temperature PbSe detector was used in a laboratory unit for gas chromatographic experimentation and em-

ployed fairly simple electronic circuitry combined with a commercial lock-in-amplifier for signal processing.

The fixed wavelength radiometer used a Hamamatsu P791-01 PbSe photoconductive cell as the sensing element. The sensitive area was arranged in a 1×3 mm slit shape. The radiometer employed a 600 Hz chopper motor and chopper frequency/phase reference circuit, mechanical phase adjustment, one-inch diameter Optical Coatings Laboratories narrow bandpass filters (with the bandpass centered for either 2.7 or 4.45 μm), an aperture for field-of-view limitation, a preamplifier circuit, and a dedicated synchronous detector.^[9] The radiometer was mounted on a rigid metal base, which served as an optical rail. This allowed for accurate aiming of the system.

Feasibility testing of the radiometer was accomplished by using a Perkin-Elmer atomic absorption (AA) burner, modified to allow the introduction of liquid compounds, via its nebulizer, into an acetylene/air flame. Flame fuel and oxidant gases were controlled using Cole-Parmer flow meters with integral flow valves. The burner system was used to ascertain the response of the radiometer to specific organic functional groups and solutions of inorganic compounds.

Instrument testing, involving rocket motor plumes, took place at Hercules Aerospace, McGregor, Texas. The building where the rocket test motors were fired was approximately 100 feet (30.5 m) from the control bunker. The motors were mounted in a steel cradle, parallel to the ground, and connected to ignition cables stretched from the bunker for computer controlled firing. A pulse from a rocket ignition control system logic board was used to trigger a Metrabyte DAS-20 analog-to-digital (a/d) converter board, installed in a Compaq 80286 portable computer, to initiate data collection. The data were stored in voltage/time pairs. Data were also obtained simultaneously from a pressure transducer on the rocket motor. Data were collected for several rocket propellants including: a low-smoke formula, an aluminized formula, and an experimental formula. The experimental formulation was subjected to fifteen trials.

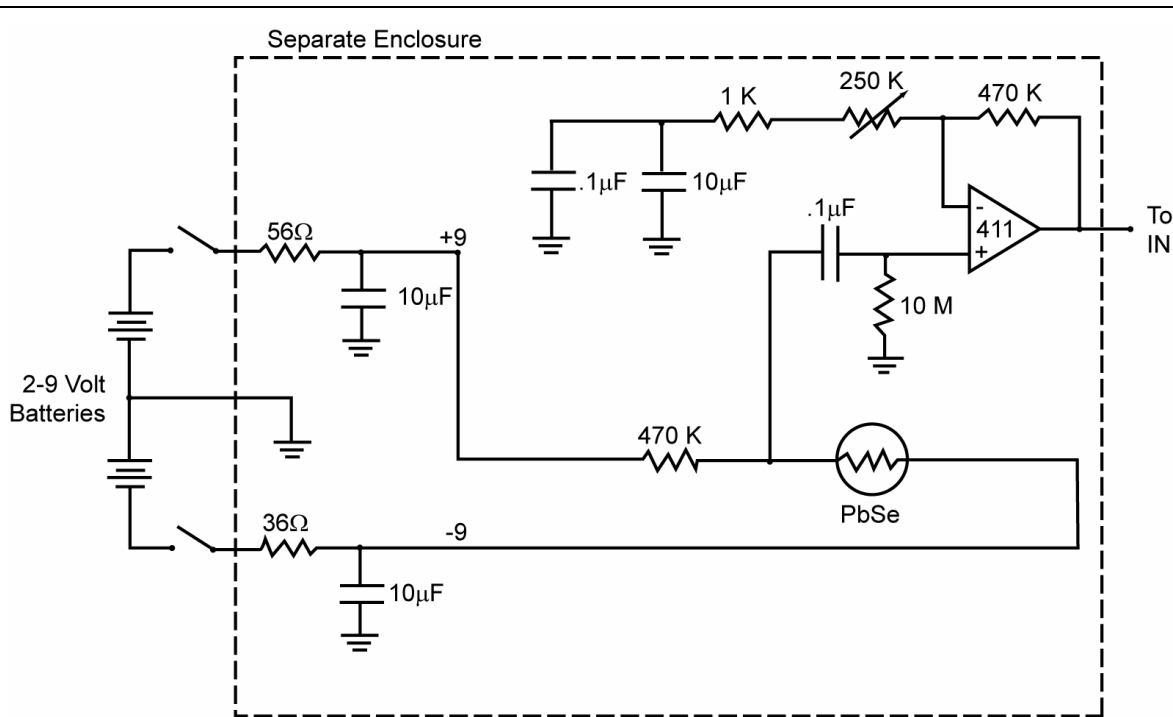

Figure 2. Detector and pre-amp circuitry.

Spectroradiometer

Modifications were made to the fixed wavelength radiometer design to produce a spectroradiometer. The electronic circuitry was improved. The original preamplifier and synchronous detector circuits were combined with a reference circuit designed to allow offset adjustments for electronically locking to the chopper phase angle. The new circuitry also provided RC time constant adjustment using a potentiometer. Schematics of the electronic cir-

cuits are shown in Figures 2–4.

Once again, the sensing element for the spectroradiometer was a 1×3 mm PbSe detector. To decrease noise, the detector circuitry was housed in a brass enclosure, and the detector was powered by two 9-volt batteries. The batteries were center tapped to ground to provide bipolar outputs. The system was mounted on a rigid metal base similar to the fixed wavelength radiometer. The bandpass filters were replaced by an Optical Coatings Laboratories circular

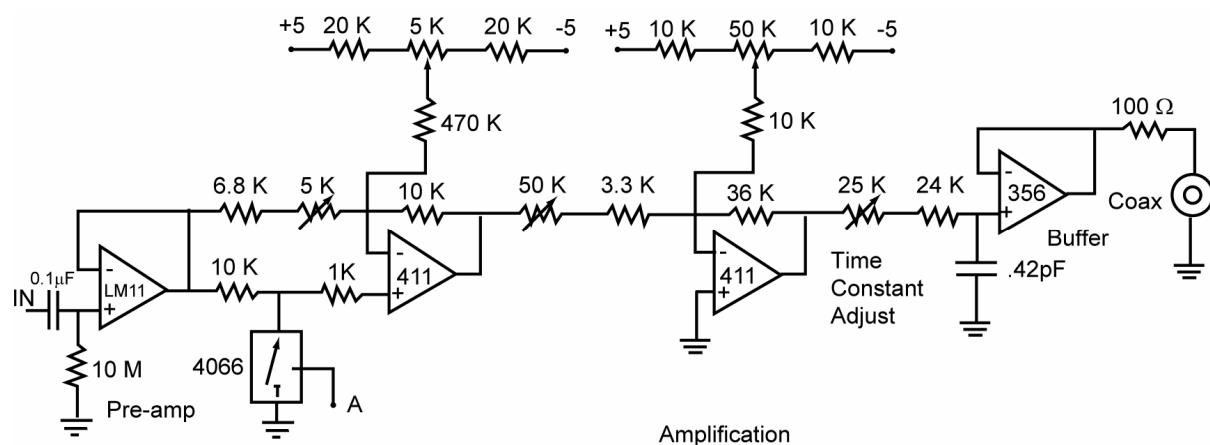

Figure 3. Synchronous detector circuit.

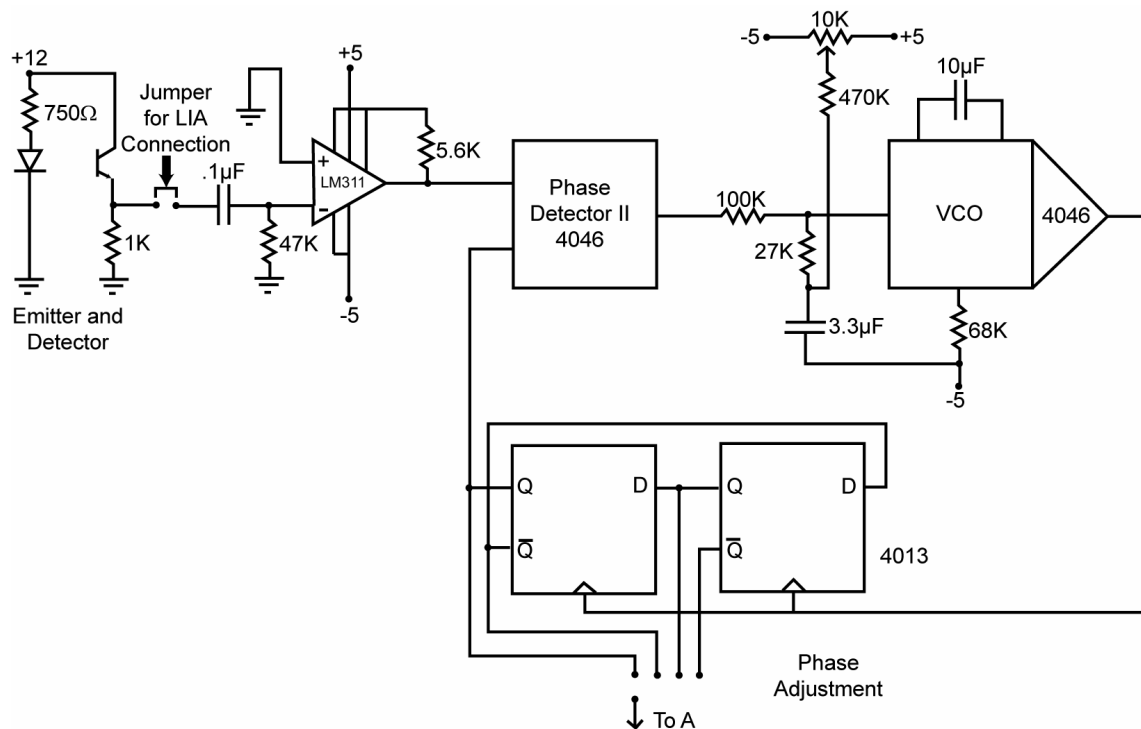

Figure 4. Reference circuit.

variable filter (CVF). The wavelength range for the CVF was 2.1 to 4.7 μm . The CVF was placed in a wheel mounted to a Superior Electric Slo-Syn MO61 stepper motor. The stepper motor was powered by a 12-volt B&K Precision model PR-3A power supply and controlled by a Metrabyte MSTEP-5 stepper motor controller board, installed in a BEST 16 MHz 80386-SX portable computer.

Data were obtained from rocket motor tests. Twenty-eight tests were completed. The three classes of rocket propellants tested were fuel-rich, aluminized, and low-smoke. The stepper motor was computer controlled from the bunker via a Metrabyte CACC-2000 ribbon cable plugged into a Metrabyte STA-STEP screw terminal box. The screw terminal box provided terminals for the connection of wires from a 100-foot (30.5-m) eight-conductor cable. The cable was then attached to the spectroradiometer. The data were collected using a Computerboards CIOAD-16F a/d converter board using a 100-foot (30.5 m) RG58 coaxial cable. All data acquisition and stepper motor control functions were performed by software written in Borland Turbo C version 2.01 language. The software

allowed the user to enter an approximate burn time of the flame/plume of the rocket motor, a file number for saving the data file, and to choose whether the entire wavelength range should be scanned, or the CVF should be parked at a specific wavelength. The software initiated when the a/d converter board was triggered by a falling edge 5-volt pulse from the rocket ignition control system logic board.

During a scan, the entire CVF was stepped through by the motor two steps at a time. Two steps are equivalent to 3.6° , or a displacement of 0.104 μm on the filter. The number of scans possible was calculated from the burn time entered by the user. After the motor moved two steps, ten data points were taken and then averaged. This average number was assigned to a wavelength. The average and wavelength data pair was then saved to a two-dimensional array. Once the filter had been stepped the calculated number of times, the data pairs were saved in an ASCII file to the hard disk, and then to a 3.5-inch floppy disk. If more than one scan was performed, the average of each scan at each wavelength was calculated. These averages and their

corresponding wavelengths were also saved to disk.

For ease in file naming, an extension was automatically added to the file number entered by the user. Graphics commands were also saved into each file. After all of the data were saved to disk, a DOS system call ran a graphics program named DPLOT that has no user interface. The program opens the last data file saved, and using graphics commands in the file, displays a spectrum on the monitor screen.

If the user chose to monitor single band emissions (i.e., carbon dioxide at 4.4 μm) the program first instructed the stepper motor to move to the desired wavelength position. The position on the filter was known by using a roller microswitch and a groove cut into the wheel as a base for measurement. When the program instructed the stepper motor to proceed to the base point, the motor rotated the wheel until the microswitch was released into the normally "on" position. A change of five to zero volts signaled the stepper motor controller board that the base point had been located.

Once the movement had ceased, the program then calculated a value corresponding to the entered burn time. This number was entered into the counter. The counter counted down as the data were acquired. The data were only taken at intervals equivalent to four times the RC [RC = resistance \times capacitance] time constant; this ensured proper electronic settling time. At each interval, ten data points were taken and averaged, and the data were assigned a time (in seconds). The data pairs were then stored in a two-dimensional array. After all the data had been collected, the data were saved in an ASCII file to the hard disk and a 3.5-inch disk. DPLOT was called and the specific wavelength spectrum versus time was displayed on the screen.

Results and Discussion

Fixed Wavelength Radiometer Design and Performance

The fixed wavelength radiometer was constructed primarily to show the feasibility of using a PbSe detector, operating with relatively

simple and inexpensive electronic circuits, to detect spectral emissions from flames and rocket exhaust plumes. The PbSe detector has several advantages for detection in the one to five micrometer region when compared to other infrared detectors. The detector can be used at room temperature with high sensitivity. This eliminates the need for expensive and bulky cooling methods. The detector is also housed in a standard TO-5 transistor case; therefore, it is very small.

The radiation was chopped by a mechanical chopper at 600 Hz. This enabled the system to employ AC circuits, but with a dedicated synchronous detector substituted for the usual lock-in-amplifier. The chopping rate was chosen to be above the flicker noise threshold of the PbSe detector. Operation of the system in DC mode was possible, but stability and sensitivity would have been compromised.

One-inch narrow bandpass filters were used because of availability and ease of placement. Center frequencies were selected to closely match the gas emission band maximums for carbon dioxide and water vapor at plume temperatures. The filter for water vapor was centered at 2.7 μm with a bandwidth of 0.2 μm , and the filter used for carbon dioxide was centered at 4.45 μm with a bandwidth of 0.5 μm . To achieve maximum blackbody rejection, the bandwidths chosen were as narrow as were available. This was very important because the PbSe detector integrates the total incident signal on its active surface. If the bandpass was too large, any blackbody radiation emitted from propellant condensed phase particles would be detected.

Problems were encountered with employing these types of bandpass filters. To change wavelengths, the radiometer had to be disassembled. Once the filter had been changed, the radiometer system had to be realigned with the source of infrared radiation. This proved rather difficult and time consuming. Data could only be collected at one wavelength at a time; therefore, a spectrum analysis of one rocket motor burn was impossible. Multiple firings were required to obtain data at just two wavelengths. This was quite expensive and not very spectrally informative.

Circular apertures to limit the field-of-view were used at the entrance to the radiometer and directly in front of the PbSe detector. Due to the slit shape of the PbSe active area, and because of the placement of the rear aperture, it was expected that this aperture would change the shape of the viewed solid angle of the plume or flame. The smallest aperture opening was 1.2 mm in diameter. Considering the 1×3 mm detector area, this allowed a 1×1.2 semicircular field to be viewed. Opening the aperture to 5 mm produced an oval shaped image due to the entire 1×3 mm detector area viewing the plume or flame. This gave nearly a 3-fold increase in signal level. For all other experimental trials, the rear aperture was left in the full open position.

The front aperture modified the size of the image (i.e., viewed area). This aperture varied in opening diameter between 1.2 and 5.0 mm, allowing a large effect on the viewed solid angle and the available radiation. During experimental trials it was found that the front aperture had a great effect, seen as apparent changes in orders of magnitude of signal level. With the high intensities from the rocket plumes, the front aperture was set at about 2.0 mm. This allowed the use of most of the electronic circuit's dynamic range. Opening the front aperture to 2.0 mm and the rear aperture to 5.0 mm, the detector had an oval viewed field. The oval had a major axis of 11 mm and a minor axis of 7.4 mm.

The electronic circuits used in the radiometer were designed to be rugged, small, and to offer reliable performance as an overall package. The circuit board was mounted to the side of the optical bench near the PbSe detector. This enabled short leads to be used in connections to the detector, minimizing noise pick-up. The circuit included a preamplifier, chopper reference comparator, and a synchronous detector. This circuit replaced a lock-in-amplifier, giving a radiometer package that was portable. All of the experimental trials were run with a 250 ms time constant. A shorter time constant would have revealed more temporal detail. This fact was not apparent until the rocket data were taken in conjunction with an existing chamber pressure measurement system. An analysis of the pressure data, using a Fast Fourier Trans-

form, indicated changes occurring on a time scale closer to 10 ms.

Flame Combustion Studies — The AA burner was initially used to test the radiometer and to assess its performance. Burner studies were done with a front aperture diameter of 5.0 mm. The acetylene/air flame was adjusted to give fuel-rich, stoichiometric, and lean flames. The emission from the burner was monitored using a filter centered at 2.7 μm for the water band and a filter centered at 4.45 μm for the carbon dioxide band. This allowed a comparison of the two bands. Also, organic compounds containing various functional groups were aspirated into the flame for combustion. The relative contribution of organic structure functionality to the emission seen at each band was noted. It was found that introduction of compounds containing an alcohol functional group gave larger infrared signals. This was due to the alcohol fueling the flame. In addition, several aqueous solutions of metals were aspirated, at levels from 250 to 1000 ppm. These metals had no effect on the infrared signal. The radiometer response to metals was very important because metals, such as potassium, aluminum, zirconium, and iron, are often added to rocket propellants to modify plume signatures and propellant ballistic properties such as burn rates.

Rocket Plume Studies—The radiometer was positioned with the entrance aperture located 18 inches (457 mm) from the plume. For this preliminary set of experiments, the radiometer was mounted on a wooden box under the plume and looked up into the plume. Concerns that particles might fall into the radiometer were unfounded. The high exhaust velocities insured that any condensed phase particles would be ejected well beyond the radiometer. The radiometer location was varied from two to approximately thirty inches (50 to 760 mm) from the exit plane of the rocket nozzle to view different axial portions of the plume. As the radiometer position was varied, the curves generated were very similar, and the infrared intensity decreased as the unit was moved further from the nozzle. It was expected that the 4.4 μm carbon dioxide signal would go through a maximum as the distance from the nozzle was increased, due to afterburning with atmospheric oxygen. The actual plotted data did not indicate

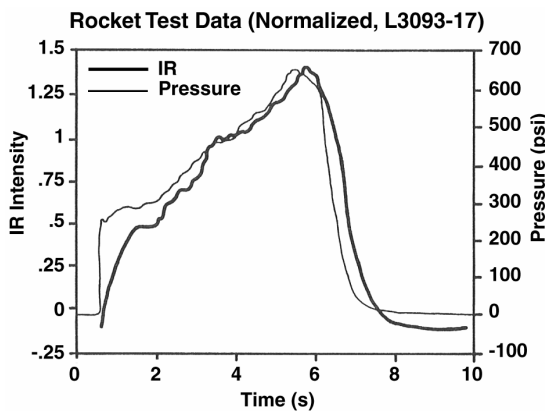

Figure 5. Carbon dioxide band infrared emission intensity and pressure data from a solid propellant taken using the fixed wavelength radiometer.

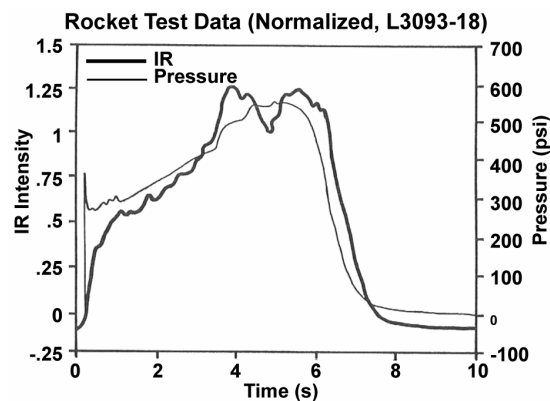

Figure 6. Carbon dioxide band infrared emission intensity and pressure data from a solid propellant taken using the fixed wavelength radiometer.

a maximum for carbon dioxide. However, the hypothesis was confirmed when the areas under the infrared intensity curves, for rocket motor tests at various distances from the nozzle, were integrated. A maximum was found for the overall IR intensity at a point 10 inches from the rocket motor nozzle.

Several plots showing infrared intensity as a function of pressure were made and analyzed. These plots illustrated that the curve produced from the infrared emissions at $4.4 \mu\text{m}$ generally followed the curve of the internal pressure data. Figures 5 and 6 show this behavior. Note that the pressure rose rapidly at rocket ignition, while the infrared data rose more gradually. Much of this effect was due to the 250 ms time constant, which effectively averaged the data with respect to time. This was also seen at burnout. However, the infrared data indicated greater magnitude changes, especially in Figure 7. The infrared data in Figure 7 showed a sharp rise in emission just before burnout. This was noted by the operators as an audible change in rocket exhaust noise pitch, which was somewhat indicative of thrust. It was thought that this anomaly might be due to the final portion of the propellant casting tearing loose from the front of the rocket motor inner casing, causing an increase in propellant surface area. It was interesting that this effect was exhibited in the infrared data, but not in the internal pressure data.

Two trial runs each of a smoky and a clean burning propellant formulation were compared. While not entirely conclusive, these runs indicated that a visible difference in particle emissions or smoke does not allow the prediction of infrared emissions. Therefore, the industry practice of watching a videotape of trial runs cannot be used to predict the infrared signature of a rocket motor. It certainly cannot quantify the emissions.

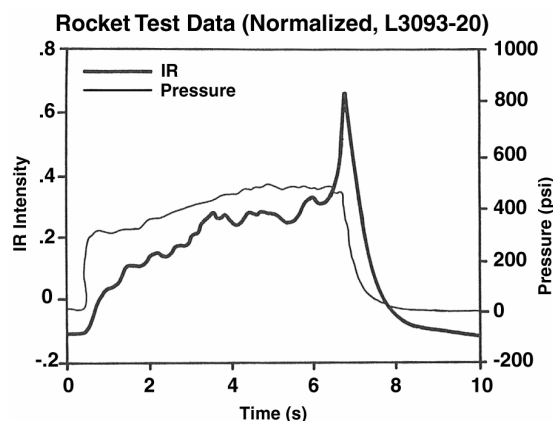

Figure 7. Carbon dioxide band infrared emission intensity and pressure data from a solid propellant taken using the fixed wavelength radiometer.

Spectroradiometer Design and Performance

After the feasibility of using a PbSe detector and simple electronics in flame/plume studies was proven, modifications were made to the fixed wavelength radiometer design. The first modification addressed the problem of changing bandpass filters. A circular variable filter was chosen to replace the bandpass filters. The CVF was ideal for the modified system since it functions like an interference filter. The spectral characteristics depend on the refractive indices of the individual films, the substrate, and the incident medium. The wavelengths passed by the filter vary according to the thickness of the coatings. In the CVF, the thicknesses are varied linearly with angular position on the substrate. All filters are designed to have a deviation of less than three percent from a straight line.

The CVF used in the spectroradiometer had a wavelength range from 2.1 to 4.7 μm . The filter covered a 90° angle and had a quartz substrate. The bandwidth for the filter, with an aperture of 1.0 mm, was approximately 0.04 μm . A four-inch (102 mm) diameter aluminum wheel was designed to house the filter. A slot was cut for the filter, with a narrow lip used for support of the filter. The filter was then affixed using silicone rubber. This type of mounting was employed because of the relatively fragile nature of the CVF.

A stepper motor was used to move the filter for scanning. The filter wheel was attached to the hub of the stepper motor for ease of rotation. To operate the motor, computer control was required, which used a stepper motor controller board installed in a computer. A software program was written to achieve motor control. At first, the motor was single-stepped, where one step was equivalent to 1.8°. However, rocket motor burn time constraints dictated that the motor had to be moved in sets of two steps or 3.6° per set.

The next step was the design of the mechanism for finding a base point on the wheel. A notch was filed in the edge of the filter wheel approximately equal to one step. The notch was used to turn a roller microswitch to the on position when it was released, as the wheel rotated. When the switch turned on, a signal was sent to the stepper motor controller board, which lo-

cated the base point. Once the base point was known, the number of steps to specific wavelengths on the filter was calculated.

Electronic circuit design was the next concern. The electronics used in the fixed wavelength radiometer were sufficient for feasibility studies; however, they did not allow for easy adjustment of parameters. In the radiometer, the time constant was hardwired on the circuit board. The electronics in the spectroradiometer were redesigned to provide time constant adjustment from 100 down to 10 ms using a potentiometer. The electronics in the fixed wavelength radiometer also did not allow phase adjustment since the phase was adjusted mechanically. This caused repeatability problems in phase settings. The electronics for the spectroradiometer were designed for electronically locking to the phase of the reference.

After the circuits were built, the line driver output randomly oscillated. This oscillation was stopped when the PbSe detector circuitry was enclosed in a brass box. To avoid noise problems, the detector was powered by two 9-volt batteries, and various capacitor values were optimized.

It was decided that the data should be collected at intervals of four times the time constant to ensure electronic settling. Data were obtained from Bunsen burner flames using the a/d converter board. The purpose of these first experiments was to ascertain the response of the spectroradiometer with the CVF in place. The flame tests were also used to ensure that the position on the filter corresponded to the correct wavelength assigned by the software. During the original experiments, short lengths of coaxial cable and eight-conductor cable were employed for data acquisition and stepper motor control. After successful experimentation, the cable lengths were changed to 100 feet (30.5m). This was necessary to ensure proper functioning of the instrument when it was used at Hercules Aerospace.

Rocket Plume Studies—Twenty-eight rocket motor tests were performed. During these tests, it was determined that the aperture on the front of the spectroradiometer needed to be fully opened to 5.0 mm since the CVF transmittance was less than the bandpass filters. This allowed

for an oval viewed area on the plume. The oval had a major axis of 19.40 mm along the axis of the plume, and a minor axis of 15.81 mm.

Various propellants were used to determine the spectroradiometer's response. The propellants were classified as: low-smoke, aluminized, and fuel-rich. Figures 8 to 11 show examples of spectra obtained during the testing. Figures 8 and 9 are motor tests using two different low-smoke propellants. Both low-smoke propellants have the same elements present, but the elements are at varied concentrations. The emissions in these two spectra look like typical rocket and flame emissions found in the two to five micrometer region. The bands centered at 2.7 and 4.4 μm are due to water vapor and carbon dioxide, respectively. The carbon dioxide peak does not exhibit the two lobes seen in the Bunsen burner spectrum. This is because spec-

tra taken with the spectroradiometer have very little spectral detail due to the speed of the scan and the resolution used in obtaining data. Due to the short duration of rocket motor burns, less than two seconds, it was necessary to step the filter two steps at a time. This allowed a full scan to be performed in 0.6 seconds. Stepping two steps at a time decreased the maximum resolution of the system approximately three times, from 0.04 to 0.104 μm . However, this operation allowed scan averaging, while permitting dynamic plume monitoring. Although the resolution had dropped, information could be discerned from the spectra. One detectable feature was the hydrogen chloride band centered at 3.5 μm .

The rocket propellant used to produce Figure 11 was fuel-rich. When the spectrum was viewed, it appeared that the instrument was

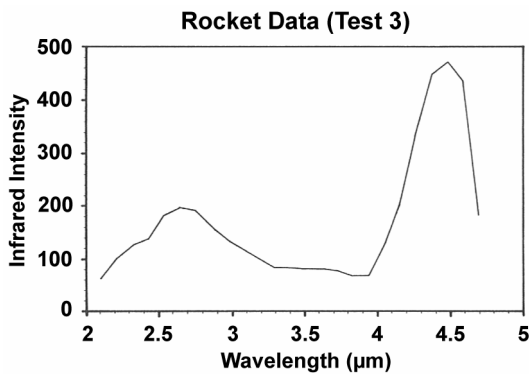

Figure 8. Infrared spectrum of a low-smoke propellant taken using the spectroradiometer.

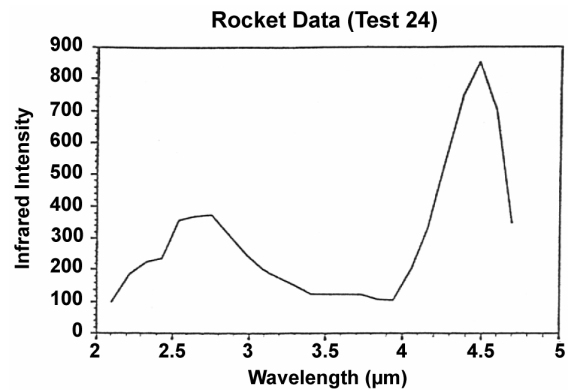

Figure 9. Infrared spectrum of a low-smoke propellant taken using the spectroradiometer.

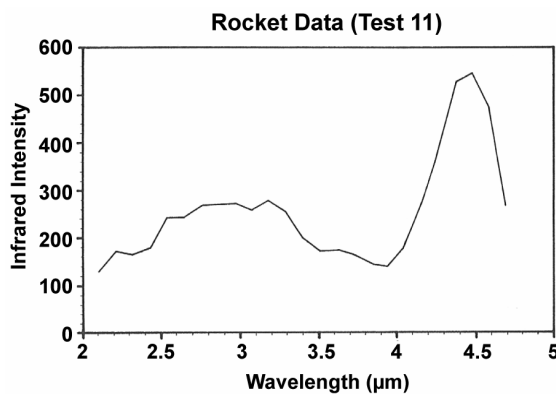

Figure 10. Infrared spectrum of an aluminized propellant taken using the spectroradiometer.

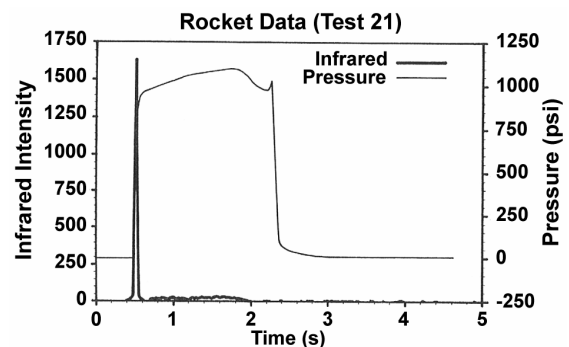

Figure 11. Carbon dioxide band infrared emission intensity and pressure data from a fuel-rich propellant taken using the spectroradiometer.

malfunctioning. All that was present in the spectrum was the igniter spike. The instrument was tested using a hot soldering iron. Once the instrument was shown to be functioning, further fuel-rich tests were run. All of the tests produced the same results: detection of the igniter spike and negligible infrared intensity afterwards. The fuel-rich motors may not have had sufficient oxygen content to give complete oxidation to final combustion products. This would result in a predominantly particulate and/or hydrocarbon output, which may not give significant infrared emissions in the two to five micrometer region. The fuel-rich tests proved that even though a smoky plume may be present, the detected infrared energy, in the two to five micrometer region, could be negligible.

Figure 12 shows infrared intensity and pressure data taken with the spectroradiometer. The CVF was parked at $4.4\ \mu\text{m}$, which corresponds to carbon dioxide. The infrared intensity and pressure curves are very similar. The 10 ms time constant allows the infrared intensity curve to follow the pressure curve directly. The 250 ms time constant used in the fixed wavelength radiometer caused the infrared intensity to slope up more slowly. A large amount of temporal detail was revealed with the shorter time constant. Further testing of the spectroradiometer stationed at 2.7 and $3.5\ \mu\text{m}$ produced similar results.

Conclusions

The fixed wavelength radiometer and the spectroradiometer both proved the feasibility of using PbSe detectors, in conjunction with simple electronics, to monitor emissions from flames and rocket motor plumes in the two to five micrometer region. Both of these systems were inexpensive, rugged, and portable which made field monitoring possible. The problems associated with the fixed wavelength radiometer included filter changing, difficulties found using a mechanical phase adjustment, and the length of the time constant. These were eliminated in the design of the spectroradiometer. The spectroradiometer had enough sensitivity to detect specific bands that corresponded to water vapor, carbon dioxide, and hydrogen chloride. It should also be noted that the sensitivity of the

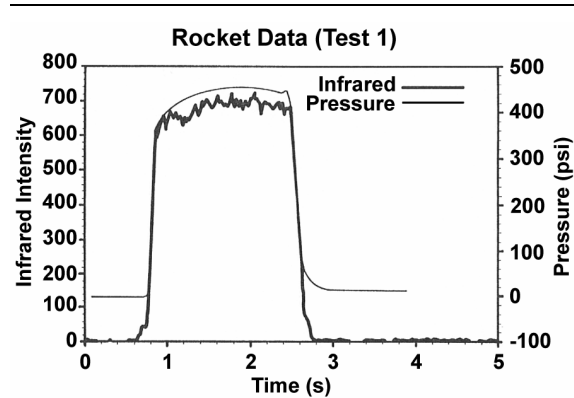

Figure 12. Carbon dioxide band infrared emission intensity and pressure data from a low-smoke propellant taken using the spectroradiometer.

spectroradiometer could be improved by scanning the CVF at a much slower rate.

The spectroradiometer enabled Hercules Aerospace to develop a spectral database based on infrared intensities produced by various propellant mixtures and motor architectures. This database was constructed by obtaining infrared data at specific wavelengths ($2.7\ \mu\text{m}$ for water vapor, $3.5\ \mu\text{m}$ for hydrogen chloride, and $4.4\ \mu\text{m}$ for carbon dioxide) and by scanning the entire CVF from 2.1 to $4.7\ \mu\text{m}$. A direct correlation between specific wavelength data and pressure data was found. As the pressure increased, the infrared intensity grew larger. Large differences between visible data, that is the amount of smoke and particulates in the plume, and the infrared intensity data were also discovered. In the future the spectroradiometer may be modified to detect emissions in other portions of the infrared spectrum. This may give more insight into the performance of rocket motors and flame-based systems.

Acknowledgments

The authors would like to express their appreciation to Robert Shanks and Reagan Cole for their assistance with electronic circuits used in this study, Armand Tomany and Lewis Neidhardt for machining work, and Mike Dugan for drafting figures. This work was supported by Hercules Aerospace. Portions of this work were presented at the 1991 Arkansas Academy of

Sciences, Fayetteville, AR, USA. This is an updated version of a paper presented at the 30th AIAA/ASME/SAR/ASEE Joint Propulsion Conference, June 27–29, 1994, Indianapolis, IN USA.

References

- 1) E. K. Plyler, *J. Res. Nat. Bur. Stand.*, Vol. 40 (1948) p 113.
 - 2) R. Ambruso and M. Slack, 4th JANNAF *Plume Technology Meeting*, Vol. 1, CPIA, 384 (1983) p 47.
 - 3) T. M. Albrechcinski and W. H. Wurster, *ICIASE '79 Record* (1979) p 57.
 - 4) H. E. Scott, J. G. Pipes, J. A. Roux, C. S. Weller, and C. B. Opal, *Proc. SPIE* Vol. 156 (1978) p 181.
 - 5) J. M. Ridout and B. C. Webb, *Proc. SPIE*, Vol. 234 (1980) p 32.
 - 6) M. K. Hudson and K. W. Busch, *Anal. Chem.*, Vol. 57 (1987) p 2603.
 - 7) M. K. Hudson and K. W. Busch, *Anal. Chem.*, Vol. 60 (1988) p 2110.
 - 8) M. K. Hudson, T. Fau, K. Underhill, and S. Applequist, *J. Chromatogr.*, Vol. 513 (1990) p 21.
 - 9) M. Mofidi, M. K. Hudson, R. Cole, and J. D. Wilson, *Proc. Ark. Acad. Sci.*, Vol. 45 (1991) p 68.
-